

W-LP/IPIR08/2M/0922-V2

2 Mega Pixel Network LPR Cameras



FEATURES

- Progressive Scan Megapixel CMOS, No sawtooth when fast moving
- 2M(1920×1080) @ 25fps (PAL) / 30fps (NTSC) high resolution,
- Dual stream support (Stream rate: 1-8M, Default stream rate 8M)
- 9-22mm Auto IRIS Varifocal IR Lens, 8Pcs Super High Power IR LED,
Available IR Distance:2-15m
- IP66 compliant
- ONVIF Profile S and Milestone Support, SDK available
- True Day/ Night Operation: IR Cut Filter (ICR)
- Support license plate recognition
- Storage: TF Card, NVR, Software Platform
- Power Supply: DC12V±10%



W-LP/IPIR08/2M/0922-V2

2 Mega Pixel Network LPR Cameras

SPECIFICATIONS

W-LP/IPIR08/2M/0922-V2	
Camera	
IP Rating	IP66
Filter	Removable IR Cut Filter
Image Sensor	Progressive Scan CMOS
Lens	9-22mm Varifocal IR Lens
Resolution	1920(H)×1080(V)
Electronic Shutter	NTSC:1/60-1/100,000s PAL:1/50-1/100,000s
Min Illumination	0Lux
Available IR Range	2 ~ 15M(6.56-49.2ft)
Video/Audio	
Video Compression	H.264
Transmission Stream Rate	Dual Stream (Code Rate:1M~8M , Default Code Rate:8M)
Frame Rate	Main Stream : 1~25fps (PAL) , 1~30fps (NTSC) Sub Stream : 1~25fps (PAL) , 1~30fps (NTSC)
Audio Compression	/
External Interface	
Network Interface	RJ45*1 10M/100M
Remote Control Interface	/
Audio Interface	/
Alarm Interface	input/output*1
Network	
Protocol	TCP/IP, UDP, SMTP, PPPoE, DDNS, SNTP, DHCP, FTP, uPnP, RTSP
Network Support	ONVIF Profile S , SDK , Milestone
Maximum Users	10
Web Language	English, Simplified Chinese, Traditional Chinese
Function	
Image Setting	OSD
Storage	TF Card, NVR, Software Platform
Video Type	Manual, Timing, Motion Detection, Alarm Video
Alarm Triggers	Motion Detection, alarm
Alarm Event	Snapshot, Video, Alarm Output, Email Upload, PTZ Drive
System/Explorer Support	Windows XP, Windows 7, IE7.0 and above
General Function	Flashing, WDR, DNR, Mirror, Watermark Overlay
General	
Power Supply	DC12V±10%
Current Consumption	770mA(Max)
Dimension	231×84×110mm(9.1" ×3.3"×4.3")
Weight	820g (28.92oz.)
Storage Temperature	-30 ~ +60°C
Operating Temperature	-30 ~ +45°C

DIMENSION

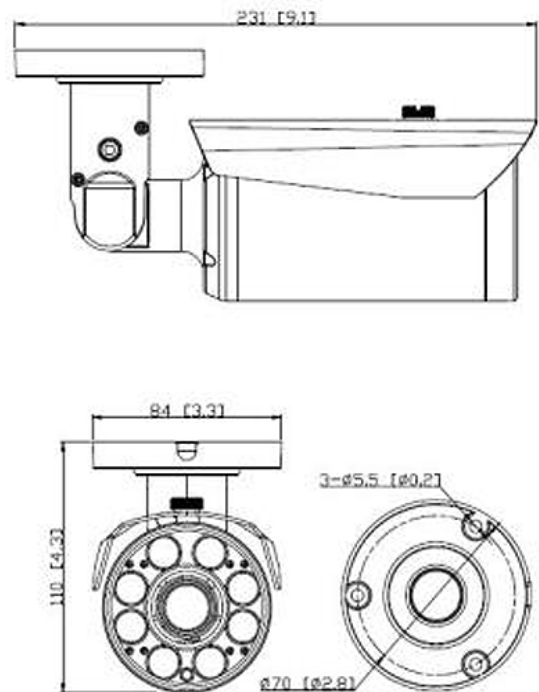

Winic Technologies USA Inc.

42 Central avenue, Farmingdale, New York 11735

Tel: +631-396-0800

Fax: +631-396-0805

Email:sales@winictech.com

www.winictech.com