

## W-PFB302S

### Wall Mount Bracket

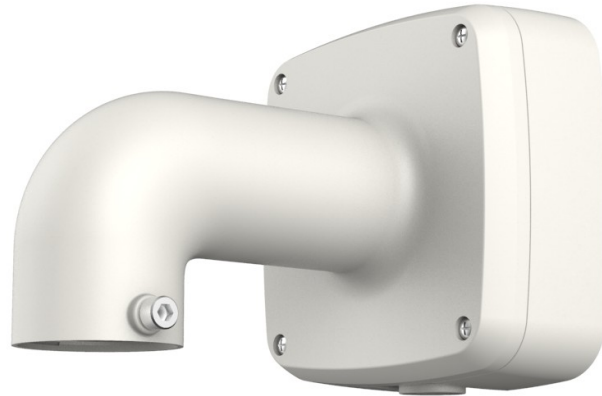

### Features

- Material: Aluminum
- Wall Mount Bracket
- Neat & Integrated design
- Junction box function

### Specifications

<b>Model</b>	<b>W-PFB302S</b>
<b>General</b>	
Material	Aluminum
Dimension (W x H x D)	134mm(W) x 134mm(H) x 187.5mm(D)
Pipe Thread	1 1/2" PF
Operating Temperature	-40°C ~60°C
Humidity	0~90% RH
Load Bearing	3.0Kg
Weight	0.7kg
Applicable Model	PFA101, PFA102, PFA103



# W-PFB302S

## Dimensions (mm)

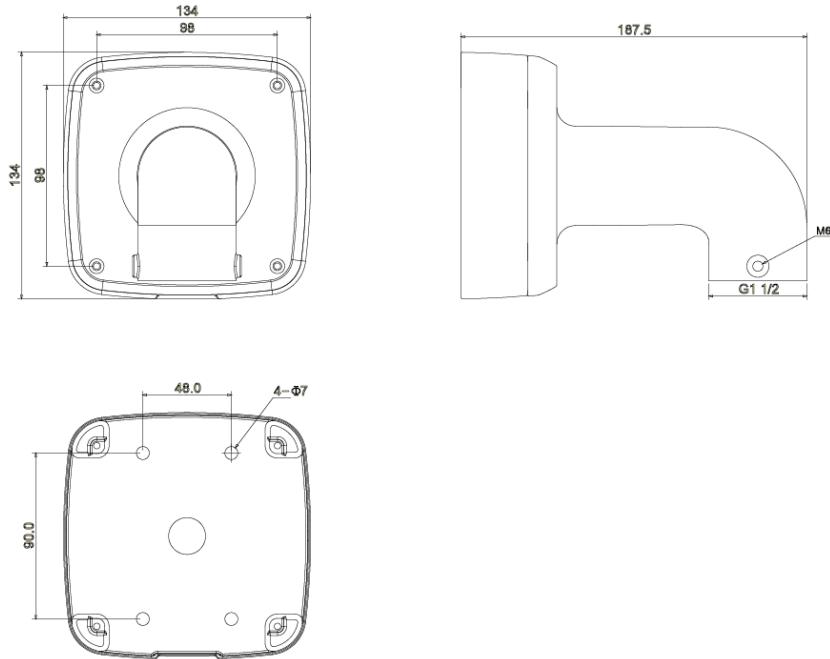

## Application

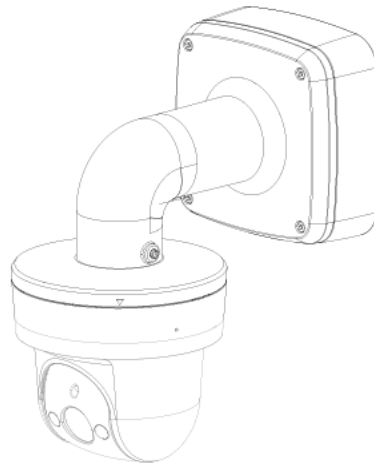

---

### Winic Technologies USA Inc.

42 Central avenue, Farmingdale, New York 11735

Tel: +631-396-0800

Fax: +631-396-0805

Email: sales@winictech.com

www.winictech.com