

W-MP350

External Microphone



The MP350 uses high-fidelity / low noise Processing chips, Voice clear, appearance fashion, which applies to a variety of situations. This product contains HIFI process chip with low noise performance. Such chip can restrain noise around environment through frequency response network for several times, and provides pure tone quality and powerful movement. The product contains dedicated AGC circuit so it is suitable for different types of Mic supervised listening environments, such as bank, prison, examination place, shopping mall, and industry factory etc. Moreover, this product has lots of virtues, including low noise, HIFI, wide range operation voltage, small electricity consumption, and long distance transmission. is a new kind of listen equipment that has adjustable sensitivity. It is a good partner to be used with supervised TV and security protection system. can be used together with camera to achieve audio and video synchronization to monitor speaking within 5~100m²

W-MP350

External Microphone

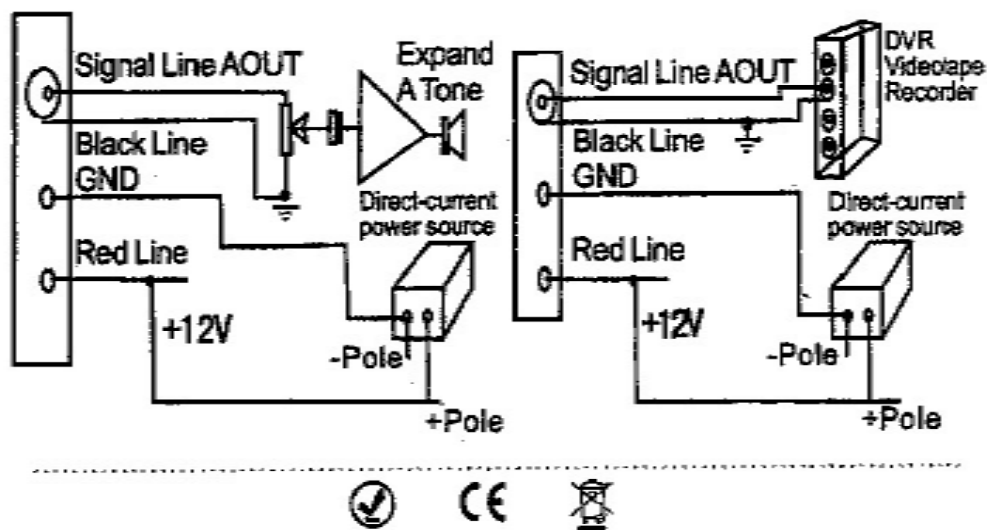

Connection Method

- 1.Red line : power (+)
- 2.Black line : power (-)
- 3.1 core shield wire : audio system input port

Electronically parameter

- Power supply : DC 6V~12V
- Dissipation circuit : 10mA
- Frequency response: 300~5500Hz, Output signal. Out impedance : 600 Ω
- Out level : 0~6V

Environment

- Temperature : -25 $^{\circ}$ C~85 $^{\circ}$ C
- Humidity:30-90%

Winic Technologies USA Inc.

42 Central avenue, Farmingdale, New York 11735

Tel: +631-396-0800

Fax: +631-396-0805

Email:sales@winictech.com

www.winictech.com