

NC328-TD-4mm

8 MP Network Dome Camera



Key Features

- Up to 8 megapixel high resolution
- Max. 3840 × 2160 @15fps
- 4 mm fixed lens
- H.265, H.265+, H.264+, H.264
- 120dB Wide Dynamic Range
- 3D Digital Noise Reduction
- DC12V & PoE (802.3af)
- IR range: up to 30 m
- Support on-board storage, up to 128 GB
- Audio I/O, Alarm I/O, optional
- Wi-Fi, optional
- IP67, IK10
- 3-axis adjustment



NC328-TD-2.8mm

8 MP Network Dome Camera

Specification

Camera	
Image Sensor	1/2.5" Progressive Scan CMOS
Min. Illumination	Color: 0.01 lux @(F1.2, AGC ON), 0 lux with IR
Shutter Speed	1/3 s to 1/100,000 s
Slow Shutter	Support
Lens	4mm, horizontal field of view: 85°
Lens Mount	M12
Iris	Manual
Day & Night	IR cut filter
DNR	3D DNR
Wide Dynamic Range	120dB
3-Axis Adjustment	Pan: 0° to 355° , tilt: 0° to 75° , rotate: 0° to 355°
Compression Standard	
Video Compression	Main stream: H.265/H.264 Sub stream: H.265/H.264/MJPEG Third stream: H.265/H.264
H.264 Type	Main Profile/High Profile
H.264+	Support
H.265 Type	Main Profile
H.265+	Support
Video Bit Rate	32 Kbps to 16 Mbps
Audio Compression (-S)	G.711/G.722.1/G.726/MP2L2
Audio Bit Rate (-S)	64Kbps(G.711)/16Kbps(G.722.1)/16Kbps(G.726)/32-128Kbps(MP2L2)
Image	
Max. Resolution	3840 × 2160
Main Stream	50Hz: 15fps (3840 × 2160), 25 fps (2560 × 1920, 2560 × 1440, 1920 × 1080, 1280 × 720) 60Hz: 15 fps (3840 × 2160), 30 fps (2560 × 1920, 2560 × 1440, 1920 × 1080, 1280 × 720)
Sub Stream	50Hz: 25fps (640 × 360, 352 × 288) 60Hz: 30fps (640 × 360, 352 × 240)
Third Stream	50Hz: 25fps (1280 × 720) 60Hz: 30fps (1280 × 720)
Image Enhancement	BLC/3D DNR
Image Settings	Support rotate mode. Brightness, contrast, saturation, and sharpness are adjustable via web browser and client software
ROI (Region of Interest)	Support 1 fixed region for each stream, and face dynamic tracking
Target Cropping	Support
Day/Night Switch	Auto/Scheduled/Alarm Triggered (-S)
Audio (-S)	
Environment Noise Filtering	Support
Audio I/O	Support
Sampling Rate	Max. 48kHz
Network	
Network Storage	Support microSD/SDHC/SDXC card (128G), local storage and NAS (NFS,SMB/CIFS), ANR



NC328-TD-2.8mm

8 MP Network Dome Camera

Alarm Trigger	Motion Detection, Tampering Alarm, Network Disconnected, IP Address Conflict, Illegal Login, HDD full, HDD error
Protocols	TCP/IP, UDP, ICMP, HTTP, HTTPS, FTP, DHCP, DNS, DDNS, RTP, RTSP, RTCP, PPPoE, NTP, UPnP, SMTP, SNMP, IGMP, 802.1X, QoS, IPv6
Standard	ONVIF (PROFILE S, PROFILE G), PSIA, CGI, ISAPI
General Function	One-key Reset, Anti-Flicker, Heartbeat, Mirror, Password Protection, Privacy Mask, Watermark, IP Address Filter
Wi-Fi (-W)	
Wireless Standards	IEEE802.11b, 802.11g, 802.11n
Frequency Range	2.4 GHz - 2.4835 GHz
Channel Bandwidth	20/40MHz Support
Protocols	802.11b: CCK, QPSK, BPSK, 802.11g/n: OFDM
Security	64/128-bit WEP, WPA/WPA2, WPA-PSK/WPA2-PSK, WPS
Transfer Rates	11b: 11Mbps, 11g: 54Mbps, 11n: up to 150Mbps
Wireless Range	50 meters (The performance varies based on actual environment)
Interface	
Communication Interface	1 RJ45 10M/100M self-adaptive Ethernet port
Audio (-S)	1 audio input (line in), 1 audio output interface
Alarm (-S)	1 alarm input, 1 alarm output
On-board Storage	Built-in microSD/SDHC/SDXC slot, up to 128 GB
Smart Feature-set	
Behavior Analysis	Line crossing detection, intrusion detection, unattended baggage detection, object removal detection
Line Crossing Detection	Cross a pre-defined virtual line, up to 4 pre-defined virtual lines supported
Intrusion Detection	Enter and loiter in a pre-defined virtual region, up to 4 pre-defined virtual regions supported
Object Removal Detection	Objects removed from the pre-defined region, such as the exhibits on display.
Unattended Baggage Detection	Objects left over in the pre-defined region such as the baggage, purse, dangerous materials
Recognition	Face detection
General	
Operating Conditions	-30 °C to +60 °C (-22 °F to +140 °F), Humidity 95% or less (non-condensing)
Power Supply	DC 12V ± 25%, 6.2W PoE(802.3af, class 3), 9W
IR Range	Up to 30 m
Protection Level	IP67, IK10
Dimensions	Φ 111 × 82.4 mm (Φ 4.4" × 3.2")
Weight	500 g (1.1 lb.)

NC328-TD-2.8mm

8 MP Network Dome Camera

Dimensions

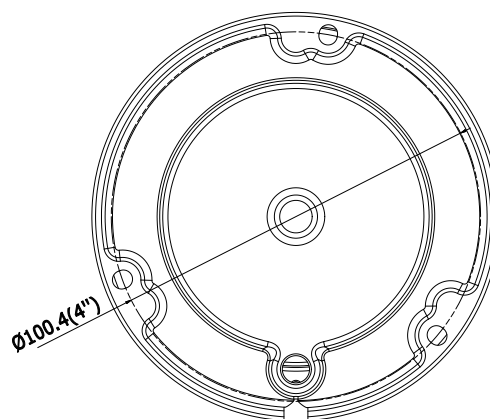
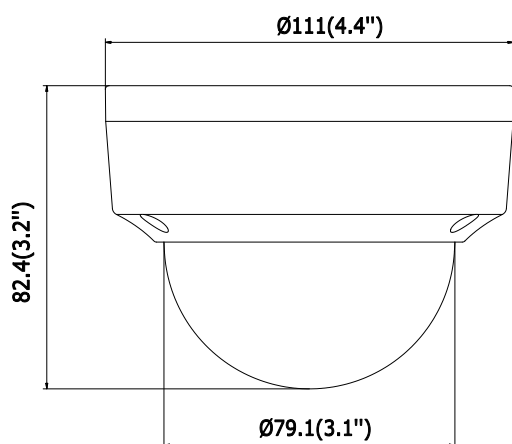

Unit: mm

Accessories



Inclined ceiling mount
1259ZJ



Wall mount
1272ZJ-110



Wall mount + junction box
1272ZJ-110B



Pendant mount
1271ZJ-110



Junction box
1280ZJ-DM18



Corner mount
1276ZJ



Vertical pole mount
1275ZJ



Rain-proof cap
1250ZJ

Winic Technologies USA Inc.

42 Central Avenue, Farmingdale, New York 11735

Tel: +631-396-0800

Fax: +631-396-0805

Email: sales@winictech.com

www.winictech.com

Design and specifications are subject to change without notice.