

## XVI-EB152T-IR-ZA

5MP HDCVI IR Eyeball Camera



**HDCVI**

- Max. 20fps@5MP
- Built-in mic
- HD and SD output switchable
- 2.7-12mm motorized lens
- Max. IR length 60m, Smart IR
- IP67, DC12V



# XVI-EB152T-IR-ZA

## 5MP HDCVI IR Eyeball Camera

### System Overview

Experience superior 5MP video and the simplicity of reusing existing coaxial infrastructure with HDCVI. The Lite series 5MP HDCVI camera features a compact design and offers a high quality image with rich details at a friendly price. It offers various vari-focal/fixed lens models with a multi-language OSD and HD/SD switchable output. Its structural flexibility and high cost-performance makes the camera an ideal choice for SMB solutions.

### Functions

#### 4 Signals over 1 Coaxial Cable

HDCVI technology supports 4 signals to be transmitted over 1 coaxial cable simultaneously, i.e. video, audio\*, data and power. Dual-way data transmission allows the HDCVI camera to interact with the HCVR, such as sending control signal or triggering alarm. Moreover, HDCVI technology supports PoC for construction flexibility.

\* Audio input is available for some models of HDCVI cameras.

#### Long Distance Transmission

HDCVI technology guarantees long-distance and real-time transmission without any loss. It supports up to 700m for 5MP HD video via coaxial cable, and up to 300m via UTP cable.\*

\*Actual results verified by real-scene testing in the test laboratory.

#### Simplicity

HDCVI technology inherits the born feature of simplicity from traditional analog surveillance system, making itself a best choice for investment protection. HDCVI system can seamlessly upgrade the traditional ana-log system without replacing existing coaxial cabling. The plug and play approach enables full HD video surveillance without the hassle of configuring a network.

#### Smart IR

The camera is designed with micro-crystalline LED IR illumination for best lowlight performance. Smart IR is a technology to ensure brightness uniformity in B/W image under low illumination. The unique Smart IR adjusts to the intensity of camera's infrared LEDs to compensate for the distance of an object, and prevents IR LEDs from overexposing images as the object come closer to the camera.

#### HD/SD Switchable

The camera supports switchable HDCVI high definition video output and CVBS standard definition video output. The two formats can be switched over through OSD menu or by PFM820(UTC controller). This feature makes the camera to be compatible with both HCVRs and existing analog DVRs and also facilitates debugging through analog testers.

#### Multi-language OSD

OSD menu provides multiple image adjustments and function settings to meet the requirements of different monitoring scenes. The OSD menu includes configurations such as back-light mode, day/night, white balance, privacy mask and motion detect. The camera supports 11 languages for OSD menu, namely, Chinese, English, French, German, Spanish, Portuguese, Italian, Japanese, Korean, Russian and Polish.

#### Protection

The camera's outstanding reliability is unsurpassed due to its rugged design. The camera is protected against water and dust with IP67 ranking, making it suitable for indoor or outdoor environments. With working temperature range of -40 °C to +60 °C (-40 °F to +140 °F), the camera is designed for extreme temperature environments. Supporting  $\pm 30\%$  input voltage tolerance, this camera suits even the most unstable power supply conditions. Its 4KV lightning rating provides protection against the camera and its structure from the effects of lightning.

## Technical Specification

### Camera

Image Sensor	1/2.7" CMOS
Effective Pixels	2592(H)×1944(V), 5MP
Scanning System	Progressive
Electronic Shutter Speed	PAL: 1/25~1/100000s NTSC: 1/30~1/100000s
Minimum Illumination	0.02Lux/F1.8, 30IRE, 0Lux IR on
S/N Ratio	More than 65dB
IR Distance	Up to 60m (197feet)
IR On/Off Control	Auto / Manual
IR LEDs	2

### Lens

Lens Type	Motorized lens / Fixed iris
Mount Type	Board-in
Focal Length	2.7-12mm
Max Aperture	F1.8
Angle of View	H: 98°~34°
Focus Control	Motorized
Close Focus Distance	500mm 19.7"

### DORI Distance

Note: The DORI distance is a "general proximity" of distance which makes it easy to pinpoint the right camera for your needs. The DORI distance is calculated based on sensor specification and lab test result according to EN 62676-4 which defines the criteria for Detect, Observe, Recognize and Identify respectively.

	DORI Definition	Distance	
		Wide	Tele
Detect	25px/m (8px/ft)	68m(223ft)	198m(650ft)
Observe	63px/m (19px/ft)	27m(89ft)	79m(259ft)
Recognize	125px/m (38px/ft)	14m(46ft)	37m(121ft)
Identify	250ppm (76px/ft)	7m(23ft)	20m(66ft)

### Pan / Tilt / Rotation

Pan/Tilt/Rotation	Pan: 0° ~ 360° Tilt: 0° ~ 78° Rotation: 0° ~ 360°
-------------------	---

### Video

Resolution	5MP (2592×1944)
Frame Rate	20fps@5MP, 25/30fps@4MP, 25/30fps@1080P
Video Output	1-channel BNC HDCVI high definition video output / CVBS video output (Can switch)
Day/Night	Auto (ICR) / Manual

OSD Menu	Multi-language
BLC Mode	BLC / HLC / DWDR
WDR	DWDR
Gain Control	AGC
Noise Reduction	2D
White Balance	Auto / Manual
Smart IR	Auto / Manual

### Certifications

Certifications	CE (EN55032, EN55024, EN50130-4) FCC (CFR 47 FCC Part 15 subpartB, ANSI C63.4-2014) UL (UL60950-1+CAN/CSA C22.2 No.60950-1)
----------------	---

### Interface

Audio Interface	Built-in mic
-----------------	--------------

### Electrical

Power Supply	12V DC ±30%
Power Consumption	Max. 8.2W (12V DC, IR on)

### Environmental

Operating Conditions	-40°C ~ +60°C (-40°F ~ +140°F) / Less than 95% RH * Start up should be done at above -40°C (-40°F)
Storage Conditions	-40°C ~ +60°C (-40°F ~ +140°F) / Less than 95% RH
Ingress Protection & Vandal Resistance	IP67

### Construction

Casing	Aluminium
Dimensions	φ122mm×104mm(Φ4.8"×4.1")
Net Weight	0.57kg (1.26lb)
Gross Weight	0.72kg (1.59lb)

# XVI-EB152T-IR-ZA

## 5MP HDCVI IR Eyeball Camera

### Accessories

Optional:

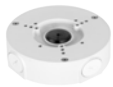

PFA130-E  
Junction box



PFB203W  
Wall mount

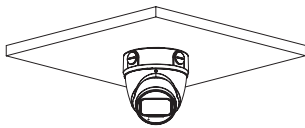
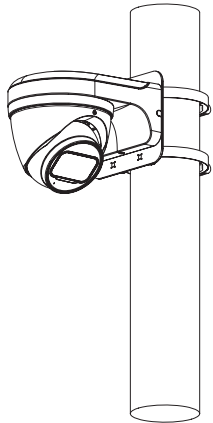
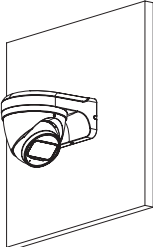

PFA152-E  
Pole mount

Junction Mount	Pole Mount
PFA130-E	PFB203W + PFA152-E
	
Wall Mount	
PFB203W	
	
Dimensions (mm/inch)	

