

# W-PFB200W

## Wall Mount Bracket

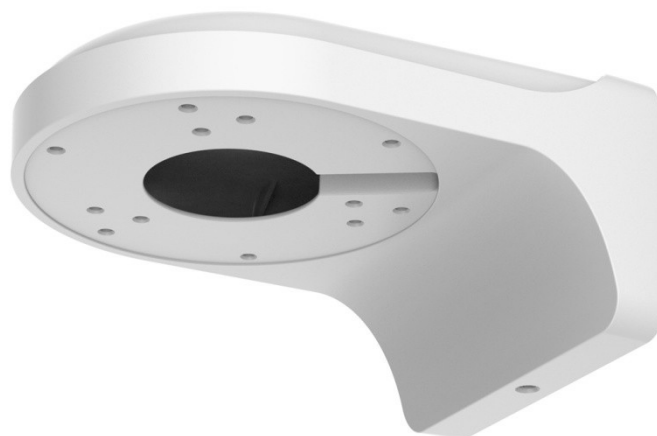

### Features

- Material: Aluminum
- Wall Mount Bracket
- Neat & Integrated design

### Specifications

<b>Model</b>	<b>W-PFB200W</b>
<b>General</b>	
Material	Aluminum & ABS
Dimension (W x H x D)	160mm(W) x 120mm(H) x 74mm(D)
Pipe Thread	N/A
Operating Temperature	-40°C ~60°C
Humidity	0~90% RH
Load Bearing	1.0Kg
Weight	1.0kg
Applicable Model	CA-DB480C, CA-DW(E/F/H/I/M), HAC-HDW1100, HAC-HDW(C/D/S), HDC-HDW2200S, IPC-HDW(C/S), IPC-HD[B](C)

# W-PFB200W

## Dimensions (mm)

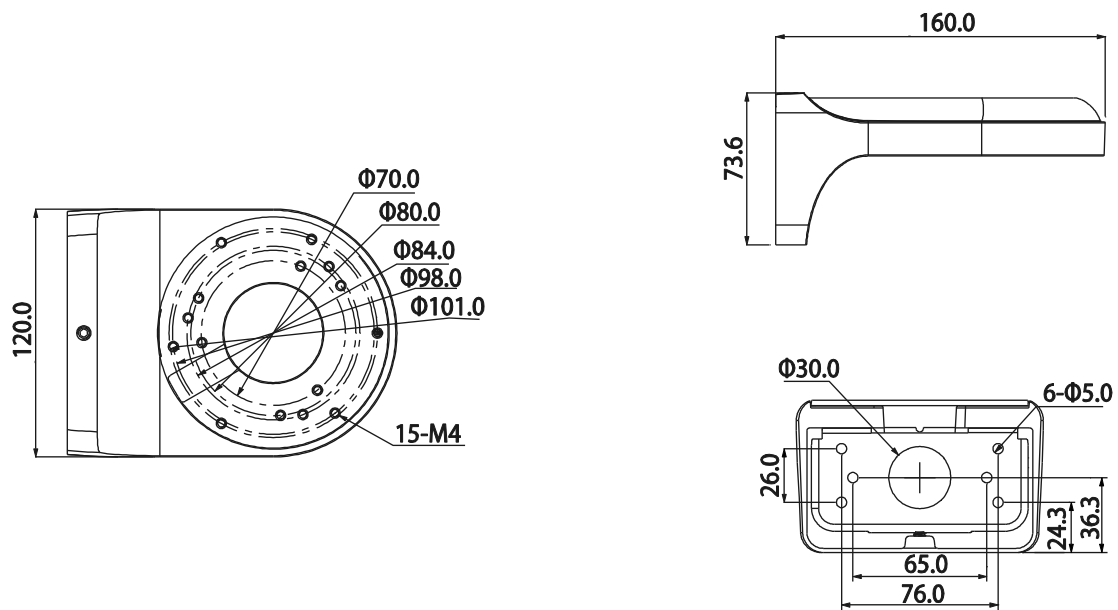

## Application

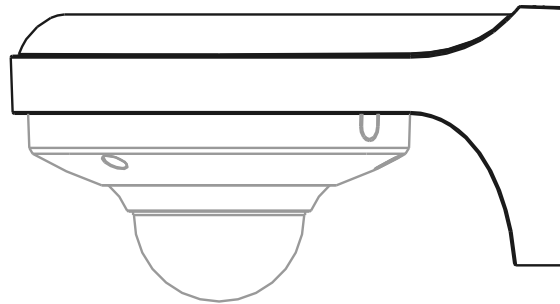

### Winic Technologies USA Inc.

42 Central avenue, Farmingdale, New York 11735

Tel: +631-396-0800

Fax: +631-396-0805

Email:sales@winictech.com

www.winictech.com