

## HAC-HDBW1100R-VF

1Megapixel 720P Vandal-proof IR HDCVI Dome Camera



### Features

- 1/2.9" 1Megapixel CMOS
- 30fps@720P
- High speed, long distance real-time transmission
- Day/Night(ICR), AWB, AGC, BLC, 2D-DNR
- 2.7~12mm vari-focal lens
- Max. IR LEDs length 30m, Smart IR
- IP66, IK10, DC12V

## Technical Specifications



<b>Model</b>	<b>HAC-HDBW1100R-VF</b>
<b>Camera</b>	
Image Sensor	1/2.9" 1Megapixel CMOS
Effective Pixels	1280(H)×720(V)
Electronic Shutter	1/60s~1/100,000s
Video Frame Rate	30fps@720P
Synchronization	Internal
Min. Illumination	0.01Lux@F1.2(AGC ON), 0Lux IR on
Video Output	1-channel BNC HDCVI high definition video output
<b>Camera Features</b>	
Max. IR LEDs Length	30m, Smart IR
Day/Night	Auto(ICR) / Color / B/W
Noise Reduction	2D
<b>Lens</b>	
Focal Length	2.7~12mm
Angle of View	H: 105.5° ~32.9°
Lens Type	Manual / Fixed Iris
Mount Type	Φ14
<b>General</b>	
Power Supply	DC12V±10%
Power Consumption	Max 3.2W
Working Environment	-30°C~+60°C / Less than 95%RH (no condensation)
Transmission Distance	Over 500m via 75-3 coaxial cable
Ingress Protection	IP66 & IK10
Dimensions	Φ122mm×89mm
Weight	0.45kg

# HAC-HDBW1100R-VF

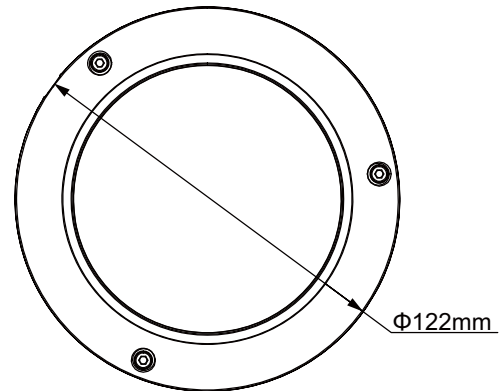
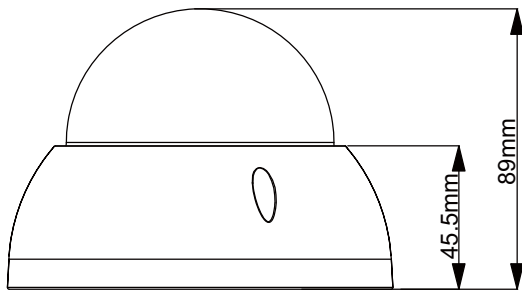
## Dimensions (mm)

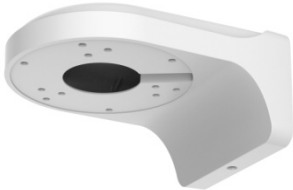

## Accessories (optional)

			
PFA123	PFA151	PFA152	PFB200W

---

### Winic Technologies USA Inc.

42 Central avenue, Farmingdale, New York 11735

Tel: +631-396-0800

Fax: +631-396-0805

Email: [sales@winictech.com](mailto:sales@winictech.com)

[www.winictech.com](http://www.winictech.com)

\*Design and specifications are subject to change without notice.